

**PROIEX**



**PDH75 SERIES DRIVE HEAD**

**INSTALLATION, OPERATION  
AND MAINTENANCE  
MANUAL**

*Version 12/02*

**PREFACE**

This manual is intended as a guide for the installation, operation and routine maintenance of Protex PDH50 series drive head.

The information, specification and illustration are up to date at time of printing. Our policy is one of continued development and therefore we reserve the right to amend any of the information contained in this manual without prior notice.

For more information about Protex PCP equipment, or technical assistance in evaluating your requirements, please contact your Protex representative.

**TABLE OF CONTENTS**

**1. Introduction**

|                                       |   |
|---------------------------------------|---|
| 1.1 Basic Description .....           | 2 |
| 1.2 Drive Specification .....         | 2 |
| 1.3 Drive Nameplate Information ..... | 2 |
| 1.4 Hydraulic Brake Assembly .....    | 3 |

**2. Installation**

|  |   |
|--|---|
| 2.1 PROTEX GDH-75 Series Drive Head Installation ..... | 3 |
|--|---|

**3. Operation**

|                               |   |
|-------------------------------|---|
| 3.1 Pre-Start Checks .....    | 4 |
| 3.2 Starting The System ..... | 5 |
| 3.3 Operating Checks .....    | 5 |
| 3.4 Troubleshooting .....     | 6 |

**4. Maintenance And Lubrication**

|  |   |
|--|---|
| 4.1 General .....                                | 7 |
| 4.2 Gearbox and Hydraulic Brake Lubrication..... | 7 |
| 4.3 Staffing Box Cap Adjustment .....            | 7 |
| 4.4 Adding Packing Rings .....                   | 8 |
| 4.5 Drive Head Removal From The Well .....       | 8 |

**5. General Assembly Component Identification**

|                                |    |
|--------------------------------|----|
| 5.1 General Assembly .....     | 9  |
| 5.2 GDH Gearbox Assembly ..... | 11 |
| 5.3 Flanged Stuffing Box ..... | 12 |

**6. Useful Information**

|  |    |
|--|----|
| 6.1 Recommended Make-up Torque for Tubing..... | 13 |
| 6.2 Sucker Rod Specification .....             | 14 |
| .....  |    |
| 6.3 Useful Formulas .....                      | 14 |
| 6.4 Conversions .....                          | 15 |

## **1. INTRODUCTION**

### 1.1 BASIC DESCRIPTION

The PROTEX GDH75 Series Drive Heads are electric motor driven fixed speed surface drive assemblies each consisting of: an electric motor mounted on a hinged motor mount support bracket, pulley belt drive inside a hinged belt guard, hydraulic backspin brake, a hollow shaft gearbox containing radial and thrust bearings and a hollow drive shaft, a drive support frame, a separate stuffing box cap and receiver, and a polished rod clamp. The drive heads are available with standard TEFC, explosion proof, IP55, etc. motors and for worldwide voltage requirements: 460V & 600V 60 HZ and 380V & 500V 50 HZ.

### 1.2 GDH75 DRIVEHEAD SPECIFICATION

|                             |  |
|-----------------------------|--|
| Recoil control system       | Sundstrand gear pump                               |
| Recoil engagement system    | Dawg control clutch                                |
|                             | - Adjustable recoil control speed                  |
|                             | - Hydraulic brake components housed inside gearbox |
|                             | - Only moving parts in forward motion are bearings |
| Drive head shaft type       | Hollow shaft                                       |
| Removable seal unit         | Split wellhead mounting assembly                   |
| Polished rod size           | 1-1/4" or 1-1/2"                                   |
| Maximum polished rod torque | 1,800 ft.lbs brake torque                          |
| Drivehead ratio             | 1 : 1  |
| Oil capacity                | 32 liters  |
| Recommended oil             | 75W90 partial synthetic gear oil                   |
| Maximum HP                  | 75 HP  |
| Motor door                  | Pre-drilled 10 - 75 HP                             |
| Motor sheave                | 6" - 12" 4VC                                       |
| Maximum driven sheave size  | Up to 30" 4VC                                      |
| Trust bearing load rating   | 194,000 LBF (L10)                                  |
| Belt guard                  | Fully enclosed - hinged                            |
| Drivehead weight            | 1,150 lbs  |
| Overall height              | 44"  |

### 1.3 DRIVE NAMEPLATE INFORMATION

The PROTEX GDH75 Series Drive nameplate is located on the main bearing housing. The model, part number and serial number are stamped here before the

drive is shipped from the factory. All of these numbers are important when ordering replacement parts.

#### 1.4 HYDRAULIC BRAKE ASSEMBLY

The Hydraulic Backspin Brake Assembly is an important safety device on all PROTEX Drive Heads. The hydraulic pump is a shaft mounted, controlled release brake system designed to impede reverse rotation of the rod string and all drive head rotating parts. The speed of reverse rotation controlled with the brake to prevent a potentially dangerous situation where pulleys can exceed their critical velocities and explode. Through the controlled release valve the reverse speed is reduced maintaining safe operation for equipment and personnel. See the Operation Section of the PROTEX Technical Manual for further detailed instruction of brake operation and maintenance.

## **2. INSTALLATION**

The following describes the installation of the PDH75 Series Drive head once the rotor and stator have been installed in the well.

#### 2.1 GDH75 SERIES DRIVE HEAD INSTALLATION

The GDH75 Series Drive head is normally shipped from the factory and to the well site completely assembled and pre-tested. Lifting of the drive head assembly is accomplished by using the lifting eyes strategically located on each drive assembly.

The hollow shaft is designed for a specific polished rod diameter either 1-1/4" or 1-1/2" depending on the model. The receiver connection is specified at the time of order and is normally a flange or thread type specific to the wellhead connection. Refer to Figure 5.1 and 5.3 for drive head component descriptions used in the following installation instructions.

**A.** Determine the sucker rod spacing. Measure the height of the drive head to the point where the polished rod clamp (Figure 5.1, #8) will be positioned during operation. Add this distance to the operating position marked on the rods during spacing. Pullout enough sucker rods to allow for installation of the polished rod using pony rods to make up any extra distances. Install any pony rods and the polished rod into the well leaving the previously measured distance to the polished rod clamp operating position plus any additional polished rod length to be extended above the clamp sticking up above the top wellhead connection. Slide ring gasket over the polished rod. Loosen stuffing box cap and lubricate packing with a light grease or WD-40. Install the stuffing box over the polished rod and connect it to the wellhead. Install the polished rod clamp (Figure 5.1, #8) to support the rod string on the top of the stuffing box cap (Figure 5.3, #2).

#### **CAUTION**

- DO NOT allow more than two (2') feet of polished rod to extend above the polished rod clamp. A length of more than two (2') feet could allow the polished rod to bend during operation.

**B.** Remove the pony rod used to lift the polished rod. For ease of installation spray the polished rod with a lubricant. Lift the remaining

drive head assembly with the sand line or another lifting line using the lifting eyes located on the assembly.

Note: Slowly lower the assembly onto the polished rod.

Lower the assembly and connect the bottom flange of the drive support frame (Figure 5.1, #14) to the stuffing box (Figure 5.1, #1). Align the bolthole patterns. Install and tighten all nuts and bolts.

**C.** Attach a short pony rod to the top of the polished rod to support the weight of the rod string using a standard rod elevator. Remove the lifting line(s). Remove the polished rod clamp (Figure 5.1, #8) from above the stuffing box cap (Figure 5.3, #2).

**D.** Install the polished rod clamp in the Operating Position and lower it onto the hollow shaft (Figure 5.2, #5). Be sure the hollow shaft engages the polished rod clamp. DO NOT leave more than two (2') feet of polished rod extended above the polished rod clamp. (Less is better). Remove the rig line elevators and the pony rod from the top of the polished rod.

**CAUTION**

- Leave a rod coupling tightened to the top of the polished rod to insure the polished rod will not pass through the hollow shaft should the polished rod clamp slip.

Note: if thread connections are used

It is essential to make sure all the threaded connections are straight and the drive head is accurately aligned with the tubing. This will reduce the potential for bending the polished rod below the head, which can eventually cause a bending fatigue failure.

Attach safety chain to flow line. Make sure that the chain is shortened up so it is tight. Also insure that the chain is oriented properly so it will hold drive unit from turning from torque.

**3. OPERATION**

**3.1 PRE-START CHECKS**

Before starting the GDH75 Series Drive System, review the installation procedures outlined in Section 2. Make sure that each piece of equipment has been installed correctly. Make sure the electric motor is wired to the power source as per the manufacturer's recommendations. Remove belts, and check rotation of electric motor, motor pulley must rotating clockwise direction (if facing the motor pulley). Check the engagement of the polished rod clamp with the hollow shaft, prime mover and rod rotation, pulley bushing tightness, pulley alignment, belt tension, check the flowlines are open and fitting alignments before starting the pump. Tighten the stuffing box cap only hand tight before starting the pump. Over tightening could cause the packing to not seat properly. Secure the leakage retainer to the top of the stuffing box cap and position the leakage relief hose to vent into a separate container or back into the wellbore. Check oil level in Gearbox before starting the system. Visually check for proper installation.

### 3.2 STARTING THE SYSTEM

After completing the pre-start checks outlined in Section 3.1, the system is ready to start.

#### **WARNING**

- ALWAYS install all safety guards such as the belt guard prior to starting the system.
- Only start up from Electrical Panel.

Start the pump and use a current ammeter to observe the motor load. Upon start-up the motor load will peak then drop as the motor reaches speed. It will climb again as the rods turn until enough torque is generated to rotate the rotor inside the stator. When the starting torque of the pump is overcome the amperage will again drop and should remain steady except for increases in pump load or differential pressure.

The motor load will increase as the fluid level in the well lowers to equalize at the dynamic fluid level corresponding to the pump production rate and the well inflow rate. There will be a time lapse before fluid reaches the surface. This time lapse varies depending on the fluid level at start-up, the annular space in the production string and the pumping rate.

As fluid reaches the surface fluid may begin to leak from the stuffing box. If so, slowly begin adjusting the stuffing box cap. It is essential to properly seat the packing during this initial start-up. As leakage occurs tighten the stuffing box cap at 1/4-turn intervals and allow to operate in each 1/4-turn position for 15 minutes. Repeat 1/4 turns every 15 minutes until the leakage stops. The time required to properly seat the packing is dependent on the type of fluid being pumped, the amount of gas in the tubing string and the flowline pressure.

### 3.3 OPERATING CHECKS

- Check the temperature of the gearbox and stuffing box at start-up and again after a few hours of operation. Higher than normal operating temperatures may be noticed at start-up. This is common during the run-in period of the bearings and packing. Refer to the Maintenance and Lubrication Section of this manual for more information pertaining to normal operating temperature conditions of the gearbox.

- Check and record the amperage at start-up and again when the well conditions stabilize. Report any unusual amperage fluctuations or significant changes from one day to the next. Abnormally high-level amp fluctuations and high or low readings may be signs of pump, rod, tubing or drive head problems.

- Check all of the bolts on the drive system that are easily accessible. Vibration during operation can cause the bolts and nuts to loosen.

- Check oil level in gearbox.

### 3.4 TROUBLESHOOTING

The following are typical problems that may be encountered with any PC Pump Drive Head and the corrective procedures to be taken:

#### A. Packing Leakage

Refer to the installation instructions in Section 3.2 of this manual for proper procedures for seating the packing. Packing may leak at first until it is properly seated and run in. Adjustments to the packing compression may be required throughout the operating life of the drive head. Any time there is leakage check to confirm whether the surface pressures have increased. Check the polished rod for excessive wear any time packing is added. The position of the polished rod can be changed if excessive wear is observed in the packing area.

#### B. Heat In Gearbox.

A. As mentioned earlier, higher than normal temperature in the gearbox area is normal during the initial hours of operation. If the bearing runs hotter than normal after the drive has been in service through the initial run-in period, then this may indicate a problem. Sufficient oil level in gearbox should eliminate most problems (see Section 4).

#### C. Noise In The Gearbox

Noise emitting from the gearbox area is generally an indication of the initial stages of a bearing failure. In this case the drive should immediately be shut down and the head sent to an Authorized PROTEX Service and Repair facility to be inspected. Again, improper lubrication can lead to premature bearing failures. See Section 4.0 for proper lubrication procedures.

#### D. Seal Leakage

**Bearing Housing:** The seal located below the thrust bearing is a double lip seal that will keep the gear oil in and foreign debris out. Normally oil will not leak around this seal unless the seal is damaged. If oil continually leaks from this area, check the seal for damage. If the seal needs to be replaced, the gearbox will have to be removed from the wellhead. Follow the instructions in Section 4.4 of the Maintenance and Lubrication Section for removal of the gearbox.

#### **4. MAINTENANCE AND LUBRICATION**

##### 4.1 GENERAL

All PROTEX Drive Head Models are designed for minimal maintenance and are the easiest drives to operate and maintain. Routine adjustment of the packing compression along with gear oil level checks is required. There are no special tools required and the points of lubrication and observation are easily accessible.

##### 4.2 GEARBOX AND HYDRAULIC BRAKE LUBRICATION

The gearbox relies on an oil bath system for lubrication and recoil control. Hydraulic Brake Gear Pump is housed in gearbox oil bath and don't require any additional lubrication. PROPER OIL LEVEL IS CRITICAL.

- Recommended Oil: 75W90 Partial Synthetic
- Oil Capacity: 32 Liters
- Initial Oil Change: 6 Month
- Subsequent Oil Change: 12 Month

The drain point is a 3/4"NPT magnetic plug located on the bottom end of the gearbox. To refill unit with oil, remove the vent cap, fill unit with oil and replace vent cap. All oil changes should be performed at normal operating temperatures.

Top bearing of gearbox is housed in a sealed grease bath and requires 3-4 shots of grease at all oil change intervals.

##### *Lubricants*

- Any type of EP Lithium soap based grease is satisfactory for bearing lubrication.
- DO NOT use any sodium or calcium based grease.

Note: FOR EXTREME COLD OR HOT ENVIRONMENTS USE ANY SYNTHETIC GREASE SPECIFIED FOR THE OPERATING CONDITIONS

##### 4.3 STUFFING BOX CAP ADJUSTMENT

It is essential to seat the packing properly at the time the drive head is first installed. The procedure outlined in Section 3.2 may require some time but is necessary to prevent future packing leakage problems. Follow this procedure each time the packing requires adjustment.

The stuffing box cap does require periodic adjustment to keep the packing properly seated and compressed. When the packing can no longer be adjusted to achieve the desired seal install additional packing rings. Follow the procedure outlined in Section 4.4 for installing additional packing rings.

At the time new packing rings are installed inspect the polished rod for scoring or wear.

**CAUTION**

- Some very slight leakage helps dissipate heat from the packing area; in contrast, over-tightening the packing gland may result in premature packing seal failure, possible damage to the polished rod and overloading of the motor.

4.4 ADDING PACKING RINGS

The packing can be added without removing the drive head from the wellhead. Proper attention to cleanliness at the well site must be observed.

1. Shut off the system from Electrical Panel

**CAUTION**

Wait until the torque is released.  
Bleed any tubing pressure off before loosening the packing gland. Keep the tubing open to atmosphere while adding the packing.

2. Remove the stuffing box cap and lift out of the way. Remove the split push ring and lift the solid push ring. Remove or hang these pieces off the casting with a wire, away from the work area. Check the O-rings on the leakage retainer and solid push ring for damage and replace O-rings as required.

3. Check the polished rod for scoring and wear. If heavy scoring is present on this piece, consider raising the polished rod or replacing it. The procedure for doing this is detailed in Section 4.5.

4. Install any new packing rings as required. Be sure to properly seat and compress each ring and alternate the splits.

5. Replace or lower the push ring(s) and stuffing box cap into place and thread it down hand tight. Follow the stuffing box cap adjustment procedure outlined in Section 3.2.

4.5 DRIVE HEAD REMOVAL FROM THE WELL

The following instructions outline the procedures to remove the GDH75 Series Drive head or bearing box from the wellhead. The drive head must be removed any time work is to be performed on the pump or any time an internal component of the gearbox is to be replaced i.e., bearings, seals, etc.

1. Shut off the system and disconnect the power source.
2. Wait until the torque is completely released.

**WARNING**

## Protex Complete Integrated Solutions

E-mail: [pcp@protexcis.com](mailto:pcp@protexcis.com) · Web: <http://www.protexcis.com>  
Phone: 1-403-252-9230 · Fax: 1-403-252-9350

- DO NOT attach anything to the polished rod or attempt to remove the polished rod clamp before allowing all of the torque to dissipate from the rod string. Allow the rod string to backspin at a controlled speed until all of the torque is dissipated before attempting to lift the polished rod or remove the polished rod clamp.
- 3 After all of the torque is dissipated attach a pony rod to the top of the polished rod and support the weight of the rod string with the main rig line. Or install a second polished rod clamp above the stuffing box cap to support the rod string weight.

4. Remove the polished rod drive clamp from the top of the drive. Support the weight of the drive head assembly with the sand line or another lifting line. Disconnect the entire drive head from the wellhead or the drive support frame from the stuffing box receiver. When using the main rig line attached to the polished rod, install the polished rod clamp above the top most piece left on the wellhead to support the weight of the rod string from the wellhead.

5. With the polished rod clamp supporting the rod string remove the pony rod and rod elevator from the polished rod and strip the desired drive head components over the polished rod.

### **5. GENERAL ASSEMBLY COMPONENT IDENTIFICATION**

#### 5.1 GENERAL ASSEMBLY

Use Figures 5.1, 5.2 and 5.3 the appropriate Reference and Description indicated in Table 5.1, 5.2 and 5.3 to identify components of the PROTEX GDH75 Series Drives.

Figure 5.1

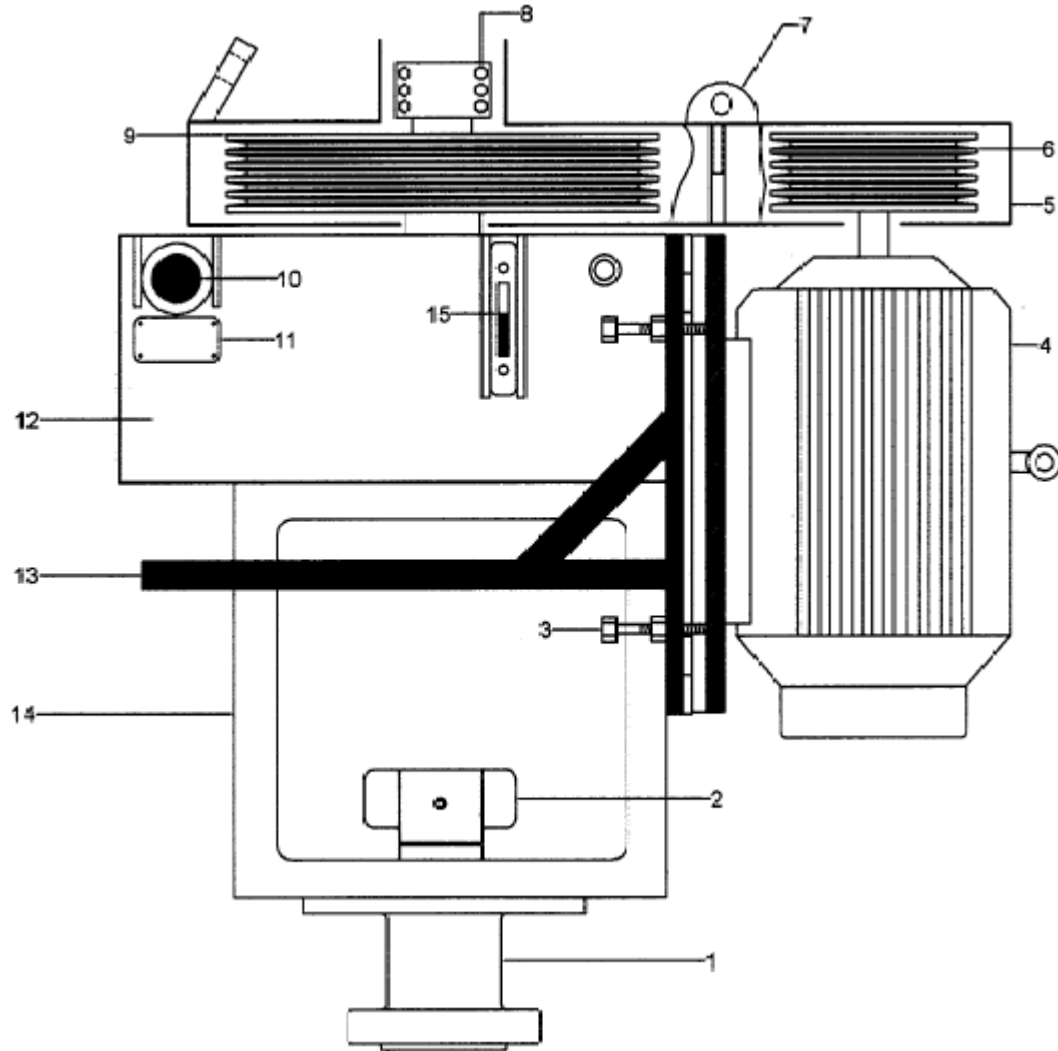

Table 5.1

| ITEM | PART NO. | DESCRIPTION           | QTY |
|------|----------|-----------------------|-----|
| 1    | GDH-SBA  | STUFFING BOX ASSEMBLY | 1   |
| 2    | GDH-SBC  | STUFFING BOX CAP      | 1   |
| 3    | GDH-BTB  | BELT TENSION BOLT     | 2   |
| 4    |          | ELECTRIC MOTOR        | 1   |
| 5    | GDH-BG   | BELT GUARD            | 1   |
| 6    |          | DRIVE SHEAVE          | 1   |
| 7    |          | LIFTING BRACKET       | 1   |
| 8    | GDH-DC   | DRIVE CLAMP           | 1   |
| 9    |          | DRIVEN SHEAVE         | 1   |

## Protex Complete Integrated Solutions

E-mail: [pcp@protexcis.com](mailto:pcp@protexcis.com) · Web: <http://www.protexcis.com>  
 Phone: 1-403-252-9230 · Fax: 1-403-252-9350

|    |           |                       |   |
|----|-----------|-----------------------|---|
| 10 | GDH-DV    | BRAKE DISCHARGE VALVE | 1 |
| 11 | GDH-IT    | IDENTIFICATION TAG    | 1 |
| 12 | GDH-GB    | GEAR BOX ASSEMBLY     | 1 |
| 13 | GDH-MSF   | MOTOR SUPPORT FRAME   | 1 |
| 14 | GDH-BOOTH | BOOTH                 | 1 |
| 15 | GDH-SG-ST | SIGHT GLASS           | 1 |

### 5.2 GDH GEARBOX ASSEMBLY

Figure 5.2

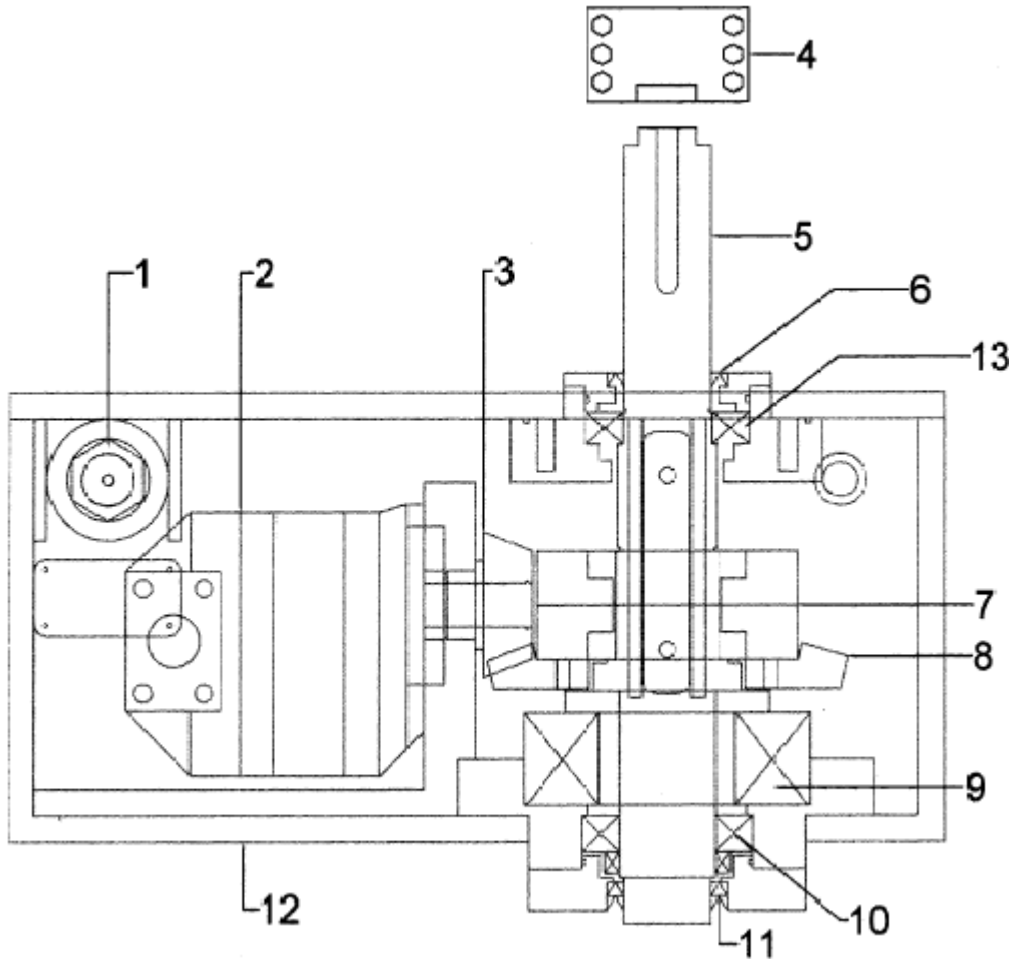

Table 5.2

| ITEM | PART NO. | DESCRIPTION             | QTY |
|------|----------|-------------------------|-----|
| 1    | GDH-DV   | SPEED ADJUSTMENT VALVE  | 1   |
| 2    | GDH-GP   | RETARDER HYDRAULIC PUMP | 1   |
| 3    | GDH-PG   | PINION GEAR             | 1   |
| 4    | GDH-DC   | 6-BOLT DRIVE CLAMP      | 1   |
| 5    | GDH-SFT  | DRIVE SHAFT             | 1   |
| 6    | GDH-TS   | TOP SEAL                | 1   |
| 7    | GDH-CA   | CLUTCH ASSEMBLY         | 1   |
| 8    | GDH-CG   | CROWN GEAR              | 1   |

## Protex Complete Integrated Solutions

E-mail: [pcp@protexcis.com](mailto:pcp@protexcis.com) · Web: <http://www.protexcis.com>  
 Phone: 1-403-252-9230 · Fax: 1-403-252-9350

|    |         |                |   |
|----|---------|----------------|---|
| 9  | GDH-TB  | TRUST BEARING  | 1 |
| 10 | GDH-BB  | BOTTOM BEARING | 1 |
| 11 | GDH-BS  | BOTTOM SEALS   | 1 |
| 12 | GDH-GB  | GEAR BOX       | 1 |
| 13 | GDH-TBG | TOP BEARING    | 1 |

### 5.3 FLANGED STUFFING BOX

Figure 5.3

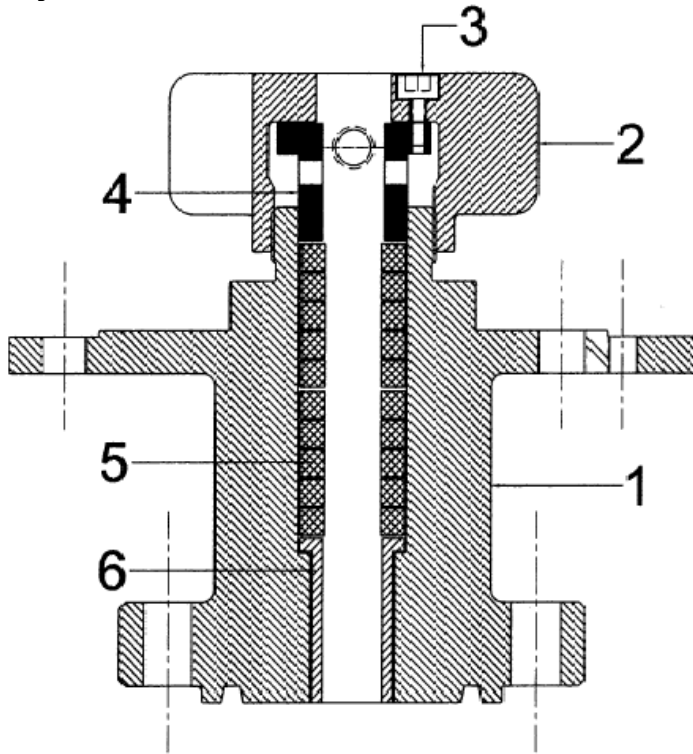

Table 5.3

| ITEM | PART NO. | DESCRIPTION              | QTY |
|------|----------|--------------------------|-----|
| 1    | GDH-FSB  | FLANGED STUFFING BOX     | 1   |
| 2    | GDH-SBC  | STUFFING BOX CAP         | 1   |
| 3    | GDH-CBB  | BRASS CAP BOLT           | 3   |
| 4    | GDH-SCB  | BRASS CAP                | 1   |
| 5    | GDH-125P | 1-1/4" OR 1-1/2" PACKING | 10  |
| 6    | GDH-RGB  | ROD GUIDE BUSHING        | 1   |

**6. USEFUL INFORMATION**

**6.1 Recommended Make-up Torque for Tubing**

| Size     |          | Weight    |             | Grade | Makeup Torque |             |
|----------|----------|-----------|-------------|-------|---------------|-------------|
| SI       | Imperial | SI        | Imperial    |       | SI            | Imperial    |
| 60.3 mm  | 2.375 in | 7.0 kg/m  | 4.7 lbs/ft  | H40   | 1340 N*m      | 990 ft*lbs  |
| 60.3 mm  | 2.375 in | 7.0 kg/m  | 4.7 lbs/ft  | J55   | 1750 N*m      | 1290 ft*lbs |
| 60.3 mm  | 2.375 in | 7.0 kg/m  | 4.7 lbs/ft  | C75   | 2310 N*m      | 1700 ft*lbs |
| 60.3 mm  | 2.375 in | 7.0 kg/m  | 4.7 lbs/ft  | L80   | 2390 N*m      | 1760 ft*lbs |
| 60.3 mm  | 2.375 in | 7.0 kg/m  | 4.7 lbs/ft  | N80   | 2450 N*m      | 1800 ft*lbs |
| 60.3 mm  | 2.375 in | 7.0 kg/m  | 4.7 lbs/ft  | C90   | 2610 N*m      | 1920 ft*lbs |
| 60.3 mm  | 2.375 in | 7.0 kg/m  | 4.7 lbs/ft  | P-105 | 3080 N*m      | 2270 ft*lbs |
| 73.0 mm  | 2.875 in | 9.7 kg/m  | 6.5 lbs/ft  | H40   | 1700 N*m      | 1250 ft*lbs |
| 73.0 mm  | 2.875 in | 9.7 kg/m  | 6.5 lbs/ft  | J55   | 2230 N*m      | 1650 ft*lbs |
| 73.0 mm  | 2.875 in | 9.7 kg/m  | 6.5 lbs/ft  | C75   | 2940 N*m      | 2170 ft*lbs |
| 73.0 mm  | 2.875 in | 9.7 kg/m  | 6.5 lbs/ft  | L80   | 3050 N*m      | 2250 ft*lbs |
| 73.0 mm  | 2.875 in | 9.7 kg/m  | 6.5 lbs/ft  | N80   | 3120 N*m      | 2300 ft*lbs |
| 73.0 mm  | 2.875 in | 9.7 kg/m  | 6.5 lbs/ft  | C90   | 3340 N*m      | 2460 ft*lbs |
| 73.0 mm  | 2.875 in | 9.7 kg/m  | 6.5 lbs/ft  | P-105 | 3940 N*m      | 2910 ft*lbs |
| 88.9 mm  | 3.500 in | 13.8 kg/m | 9.3 lbs/ft  | H40   | 2340 N*m      | 1730 ft*lbs |
| 88.9 mm  | 3.500 in | 13.8 kg/m | 9.3 lbs/ft  | J55   | 3090 N*m      | 2280 ft*lbs |
| 88.9 mm  | 3.500 in | 13.8 kg/m | 9.3 lbs/ft  | C75   | 4080 N*m      | 3010 ft*lbs |
| 88.9 mm  | 3.500 in | 13.8 kg/m | 9.3 lbs/ft  | L80   | 4240 N*m      | 3200 ft*lbs |
| 88.9 mm  | 3.500 in | 13.8 kg/m | 9.3 lbs/ft  | N80   | 4330 N*m      | 3200 ft*lbs |
| 88.9 mm  | 3.500 in | 13.8 kg/m | 9.3 lbs/ft  | C90   | 4650 N*m      | 3430 ft*lbs |
| 88.9 mm  | 3.500 in | 13.8 kg/m | 9.3 lbs/ft  | P-105 | 5490 N*m      | 4050 ft*lbs |
| 101.6 mm | 4.000 in | 16.4 kg/m | 11.0 lbs/ft | H40   | 2630 N*m      | 1940 ft*lbs |
| 101.6 mm | 4.000 in | 16.4 kg/m | 11.0 lbs/ft | J55   | 3470 N*m      | 2560 ft*lbs |
| 101.6 mm | 4.000 in | 16.4 kg/m | 11.0 lbs/ft | C75   | 4600 N*m      | 3390 ft*lbs |
| 101.6 mm | 4.000 in | 16.4 kg/m | 11.0 lbs/ft | L80   | 4780 N*m      | 3530 ft*lbs |
| 101.6 mm | 4.000 in | 16.4 kg/m | 11.0 lbs/ft | N80   | 4880 N*m      | 3600 ft*lbs |
| 101.6 mm | 4.000 in | 16.4 kg/m | 11.0 lbs/ft | C90   | 5250 N*m      | 3870 N*m    |
| 114.3 mm | 4.500 in | 19.0 kg/m | 12.8 lbs/ft | H40   | 2930 N*m      | 2160 ft*lbs |
| 114.3 mm | 4.500 in | 19.0 kg/m | 12.8 lbs/ft | J55   | 3870 N*m      | 2860 ft*lbs |
| 114.3 mm | 4.500 in | 19.0 kg/m | 12.8 lbs/ft | C75   | 5130 N*m      | 3780 ft*lbs |
| 114.3 mm | 4.500 in | 19.0 kg/m | 12.8 lbs/ft | L80   | 5340 N*m      | 3940 ft*lbs |
| 114.3 mm | 4.500 in | 19.0 kg/m | 12.8 lbs/ft | N80   | 5450 N*m      | 4020 ft*lbs |
| 114.3 mm | 4.500 in | 19.0 kg/m | 12.8 lbs/ft | C90   | 5870 N*m      | 4330 ft*lbs |

These values have been extracted from API Recommended Practice 5C1 “Recommended practice for Care and use of Casing and Tubing”. The torque values listed above represent the optimum makeup torque. The maximum and minimum torque are 75% and 125% of the optimum values, respectively.

## Protex Complete Integrated Solutions

E-mail: [pcp@protexcis.com](mailto:pcp@protexcis.com) · Web: <http://www.protexcis.com>  
Phone: 1-403-252-9230 · Fax: 1-403-252-9350

### 6.2 SUCKER ROD SPECIFICATIONS

Maximum Recommended Sucker Rod Torque Values

| NORRIS SUCKER RODS AND PONY RODS |                |               |                            |                      |                      |
|----------------------------------|----------------|---------------|----------------------------|----------------------|----------------------|
| Rod Size (Inches)                | Grade D Carbon | Grade D Alloy | Grade D Special Alloy (78) | Special Service (96) | Special Service (97) |
| 3/4"                             | 430            | 460           | 470                        | 500                  | 500                  |
| 7/8"                             | 675            | 735           | 750                        | 800                  | 800                  |
| 1"                               | 1010           | 1100          | 1110                       | 1200                 | 1200                 |
| 1-1/8"                           | N/A            | 1570          | 1590                       | N/A                  | 1700                 |
| 1-1/4"                           | N/A            | 2000          | 2100                       | N/A                  | 2500                 |

Above values are in "Foot Pounds"

Sucker Rod Weight and Dimensions

| SUCKER RODS       |                        |                 | COUPLINGS             |                     |                       |                 |
|-------------------|------------------------|-----------------|-----------------------|---------------------|-----------------------|-----------------|
| Rod Size (Inches) | T&C Weight (Lb. / Ft.) | API Thread Size | Slim Hole OD (Inches) | Regular OD (Inches) | Oversized OD (Inches) | Length (Inches) |
| 3/4"              | 1.63                   | 1-1/6"          | 1-1/2"                | 1-5/8"              | 1-13/16"              | 4"              |
| 7/8"              | 2.22                   | 1-3/16"         | 1-5/8"                | 1-13/16"            | 2"                    | 4"              |
| 1"                | 2.90                   | 1-3/8"          | 2"                    | 2-3/16"             | N/A                   | 4"              |
| 1-1/8"            | 3.67                   | 1-9/16"         | 2-1/4"                | 2-3/8"              | N/A                   | 4-1/2"          |

### 6.3 USEFUL FORMULAS

$$\text{Polished Rod Speed} = \frac{\text{Production Rate (m3/day)}}{\text{Pump Nominal Displacement (m3/day/rpm)}} + \text{Friction Torque}$$

$$\text{Torque (Ft. Lbs.)} = \frac{\text{Total Net Lift (m)} \times \text{Nominal Disp (m3/day/100rpm)}}{125}$$

$$\text{Total Net Lift (m)} = \text{Dynamic Fluid Level (m)} + \text{Flowline Backpressure (m)}$$

$$\text{Horse Power} = \frac{\text{RPM} \times \text{Torque}}{5252} = \frac{\text{Amps} \times \text{Volts} \times \text{Eff} \times \text{PF} \times 1.73}{746}$$

Where: Eff = electric motor efficiency  
PF = motor power factor

$$\text{Specific Gravity} = \frac{141.5}{\text{API} + 131.5}$$

$$\text{Belt Length} = 2C + \frac{\pi}{2}(D + d) + \frac{(D - d)^2}{4C}$$

Where: C = center distance between sheaves

## Protex Complete Integrated Solutions

E-mail: [pcp@protexcis.com](mailto:pcp@protexcis.com) · Web: <http://www.protexcis.com>  
 Phone: 1-403-252-9230 · Fax: 1-403-252-9350

Fresh Water Gradient = 0.433 PSI/Foot = 9.8 Kpa/Meter

Fresh Water Sp. Gr. = 1.0

D = pitch dia. of Drive Sheave

d = pitch dia. of Primemover sheave

### Specific Gravity/API Conversion

| Oil Density (Kg/M3) | Specific Gravity | API  |
|---------------------|------------------|------|
| 780                 | 0,780            | 49,8 |
| 800                 | 0,800            | 45,3 |
| 820                 | 0,820            | 41,0 |
| 840                 | 0,841            | 36,9 |
| 860                 | 0,861            | 32,9 |
| 880                 | 0,881            | 29,2 |
| 900                 | 0,901            | 25,6 |
| 920                 | 0,921            | 22,2 |
| 940                 | 0,941            | 18,9 |
| 960                 | 0,961            | 15,8 |
| 965                 | 0,966            | 15,0 |
| 970                 | 0,971            | 14,3 |
| 975                 | 0,976            | 13,5 |
| 980                 | 0,981            | 12,8 |
| 985                 | 0,986            | 12,1 |
| 990                 | 0,991            | 11,3 |
| 995                 | 0,996            | 10,6 |
| 1000                | 1,001            | 9,9  |
| 1020                | 1,012            | 7,1  |

### TIME REQUIRED TO FILL TUBING STRING

| Tubing Size | Pumping Rates   |               |                 |               |
|-------------|-----------------|---------------|-----------------|---------------|
|             | 25 BPD          | 5M3/day       | 100 BPD         | 20M3/day      |
| 2-3/8"      | 22 min / 100 ft | 29 min / 50 m | 6 min / 100 ft  | 7 min / 50 m  |
| 2-7/8"      | 33 min / 100 ft | 43 min / 50 m | 8 min / 100 ft  | 11 min / 50 m |
| 3-1/2"      | 50 min / 100 ft | 65 min / 50 m | 13 min / 100 ft | 16 min / 50 m |

### 6.4 CONVERSIONS

Length = Feet x 0.3048 = Meters  
 Meters x 3.281 = Feet  
 Inch x 0.0254 = Meters  
 Meters x 39.3701 = Inch

Area = Sq. Feet x 0.0929 = Sq. Meters  
 Sq. Meters x 10.764 = Sq. Feet

Volume = Cu. Feet x 0.02832 = Cubic Meter  
 Cubic Meter x 35.31 = Cubic Feet

Mass = Pounds x 0.4536 = kilograms  
 Kilograms x 2.205 = Pounds

Force = Pound·Force x 0.445 = DecaNewtons  
 DecaNewtons x 2.25 = Pound·Force

Torque = Pound·Force · Foot (lbf·ft) x 1.356 = Newton· meter (N·m)  
 Newton meter x 0.738 = Pound·Force · Foot (lbf·ft)

Pressure = PSI x 6.895 = Kpa  
 Kpa x 0.145 = PSI

Flow Rate = USGPM x 34.3 = BPD  
 USGPM x 5.451 = M3/day

## Protex Complete Integrated Solutions

E-mail: [pcp@protexcis.com](mailto:pcp@protexcis.com) · Web: <http://www.protexcis.com>  
Phone: 1-403-252-9230 · Fax: 1-403-252-9350

Barrels x 0.159 = Cubic Meters  
Cubic Meters x 6.29 = Barrels  
1 Barrel = 42 US Gallons = 35 Imperial Gallons

### **Protex CIS Ltd Warranty**

This shall be the only warranty given by Protex CIS Ltd ("Company"), and no other warranty by Company, Express or Implied, shall be applicable, including any implied warrant of merchantability or any implied warranty of fitness for a particular purpose.

Subject to the limitations and conditions herein, Company warrants its products (with the exception of rotating stuffing boxes) to be free from defects in workmanship and material under normal use and service for a period of twelve (12) months from the date of installation or eighteen (18) months from the date of shipment, whichever occurs first. Company warrants rotating stuffing boxes to be free from defects in workmanship and material under normal use and service for a period of three (3) months from the date of installation or nine (9) months from the date of shipment, whichever occurs first.

Company's obligations under this warranty shall be limited to repairing, replacing or issuing credit for, at Company's option, any product or parts it finds to be defective in material or workmanship. Company must be given a reasonable opportunity to investigate. Shipping and handling in connection with this warranty will be at customer's expense. Products sold by Company, but manufactured by another company, will carry only the warranty of the manufacturer, and the customer will rely solely on that warranty. Services provided by Company are warranted for a period of ninety (90) days from the date the services are rendered. The liability of Company for any loss or damage resulting to the customer or user or any third party from any defect in any product or service will not, in any case, exceed the selling price that Company received from the customer for the product or service. The above shall be the customer's exclusive remedy with respect to products or services. In no event will company be liable for incidental, consequential, special, indirect or other damages of any nature.

This warranty will not apply and will be void if the product fails as a result of down hole corrosion; non-compatibility of produced fluid with the stator and/or rotor; general wear and abrasion; incorrect installation, removal, use or maintenance; operation outside of the manufacturer's recommended guidelines; alteration; accident; abuse or negligence. Hydraulic wellhead drives, hydraulic power transmission units or rotating stuffing boxes sold individually for use with equipment not manufactured by Company will not be covered under this warranty.

Company does not warrant that any of the products sold by it, if used or sold in combination with other equipment or used in the practice of methods or processes, will not, by virtue of such combination or use, infringe patents of other, and Company shall not be liable for any patent infringement arising from, or by reason of, any such use or sale. Furthermore, Company shall not be liable for any patent infringement arising from, or by reason of, any use or sale of any materials, equipment or products not of Company's manufacture or for the use or sale of any materials, equipment or products, or other goods specially made, in whole or in part, to the customer's design specifications.

**Protex Complete Integrated Solutions**

E-mail: [pcp@protexcis.com](mailto:pcp@protexcis.com) · Web: <http://www.protexcis.com>

Phone: 1-403-252-9230 · Fax: 1-403-252-9350



## Protex Complete Integrated Solutions

E-mail: [pcp@protexcis.com](mailto:pcp@protexcis.com) · Web: <http://www.protexcis.com>

Phone: 1-403-252-9230 · Fax: 1-403-252-9350

Phone: 1-403-252-9250 • Fax: 1-403-252-9350 • [pcp@protexcis.com](mailto:pcp@protexcis.com) • [www.protexcis.com](http://www.protexcis.com)